



















# Contents

<i>Product</i>	<i>Type</i>	<i>Page</i>	<i>Product</i>	<i>Type</i>	<i>Page</i>
<b>FLX-REKU / FLX-REKU-OVAL FLEXIBLE AIR DISTRIBUTION SYSTEM</b>					
	FLX round flexible hose	FLX-HDPE, FLX-HDPE-A..... 524		FLX oval ducts	FLX-HDPE-132-52..... 557
	FLX plenum boxes for air valve	FLX-PLO, FLX-PRO..... 526 FLX-PLO-L, FLX-PRO-L..... 528 FLX-SRGL-320..... 530		FLX plenum boxes with oval connectors	FLX-PRV..... 558
	FLX plenum boxes for grilles	FLX-PLO-MOV..... 531		Distribution boxes	FLX-PRV-R..... 560
	Distribution boxes	FLX-PLO-R, FLX-PRO-R..... 532		FLX couplings	FLX-VNS..... 561 FLX-VODS..... 562 FLX-VBH, FLX-VBW..... 563
	Horizontal plenum boxes	FLX-PLO-PL..... 536 FLX-PLO-R-P..... 538			
	FLX silencer	FLX-SQOL..... 540			
	Offset plenum box	FLX-ODSQL..... 541			
	FLX fittings	FLX-BP..... 542 FLX-RPC, FLX-RSCL..... 543 FLX-RSFCLL..... 544 FLX-SP..... 545			
	FLX dampers	FLX-DAS..... 546 FLX-DAT..... 547			
	Couplings and other accessories	FLX-NSL..... 548 FLX-MSF..... 549 FLX-USZ..... 550 FLX-FAX..... 551			
	FLX end caps	FLX-CS-PVC, FLX-CF-PVC..... 552			
	FLX plenum boxes for air valve	FLX-PLO-50..... 553 FLX-PLO-L-50..... 554			
	Distribution boxes	FLX-PLO-R-50..... 555			
	Horizontal boxes	FLX-PLO-R-P-50..... 556			

# **FLX-REKU / FLX-REKU-OVAL**

## **Air distribution system**

## System description

The FLX-REKU air distribution ductwork consists of ventilation semi-rigid ducts, distribution and plenum boxes, ventilation dampers and other elements that, together with a heat recovery unit, constitute a complete mechanical ventilation system with heat recovery (MVHR). The FLX-REKU system is a great solution when high durability and flexibility are required. The high circumferential rigidity allows burying the ducts in concrete.

## Dimensions

Main component of FLX-REKU air distribution system is radial, semi-rigid ducting in the outer diameter  $\varnothing 50$ ,  $\varnothing 63$ ,  $\varnothing 75$  or  $\varnothing 90$  mm, with inner diameter of 40 mm, 51 mm, 63 mm or 75 mm respectively. In FLX-PLO plenum and distribution boxes duct connection spigots fit the inner dimension of the duct (male connection), while in FLX-PRO plenum and distribution boxes, duct connections spigots fit outer dimension (male connection). Main component of FLX-REKU-OVAL air distribution system is oval, semi-rigid ducting (a trapezoid-like shape) with a height of only 52mm and a width of 132mm, low profile of FLX-REKU-OVAL system allows it to be installed easily in the floor and ceiling insulation layer.

FLX-HDPE-A ducts are complying with European norm EN 17192:2018 for ridged or semi-rigid non-metallic ductwork, which defines the test methods and performance characteristics like airtightness, pressure drop, reaction to fire, resistance to external pressure, thermal resistance and microbial resistance.

## Installation instructions

FLX-HDPE ducts are pushed onto male connectors with gasket in plenum and distribution boxes (FLX-PLO) or inserted into female connectors with inner gaskets. In both cases the connection is airtight and easily made. Such ductwork can be laid in the concrete screed or inside the insulation layer. Round ducts are delivered in 50m long coils and oval in 20m ones - this minimize the need for unnecessary connections. Regardless of, system includes male and female couplings. Typically, the system consists of supply and exhaust manifolds (FLX-PLO-R or FLX-PRO-R) with the number of outlets matched to ductwork and the number of rooms, and the appropriate number of plenum boxes for valves (FLX-PLO or FLX-PRO). Each plenum box is connected to the manifold with 1,2 or 3 FLX-HDPE pipes, depending on the required airflow, while maintaining an optimal air speed (2 - 2.5 m / s). To complete the FLX-REKU system, you can use SPIRAL® system elements, such as galvanized ducts, elbows, fittings, air intakes, outlets and more. As a rule, the SPIRAL® system is used on the following sections: from intake / exhaust to air handling unit and to distributions boxes.

## Application advantages

The relatively small dimensions and an unique structure allow installing FLX ducts under the ceiling, on walls and laid on floors. The FLX ducts can be also concealed under drywall panels or wet render. The superior durability and strength of FLX materials can withstand the pressure of cast concrete and make this FLX system perfect for burying in separating floor slabs and cast-in-place flooring systems. The low-profile plenum boxes save space and usually do not require any specific finish of walls or ceiling systems. The antimicrobial lining in FLX-HDPE-A flexible ducts contains silver ions. The bactericidal and fungicidal performance of this ducting is certified with independent tests.

## How to order

Product code: FLX-PLO-R- $\varnothing d_2$ -1-2-3-4- $\varnothing d_1$

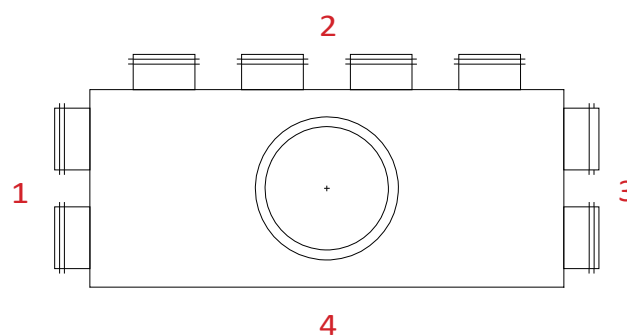

where:

- type (FLX-PLO or FLX-PRO for  $\varnothing 63$ mm)
- $\varnothing d_2$  FLX-HDPE duct connection spigot ( $\varnothing 63$ ,  $\varnothing 75$ ,  $\varnothing 90$ )
- 1-2-3-4 number and configuration of connection spigots  $\varnothing d_1$ , 80,100,125,150,160,180,200,250 mm SPIRAL duct diameter
- Z no connection spigots, DIY solution = cutting at the construction site
- F female connection / no symbol = male connection

## Connection

Typical connection diameters ( $d_1$ ) for ductwork in FLX-REKU system manifolds are  $\varnothing 100$ , 125, 160, 180, 200 or 250mm (just like the diameter of the outlets in residential air handling units), e.g. FLX-PLO-R-75-3-5-3-5-160.

FLX-PLO plenum and distribution boxes have male connections ( $d_2$ )  $\varnothing 75$  or  $\varnothing 90$  mm, while FLX-PRO ( $d_2$ )  $\varnothing 63$  mm have female ones. Plenum boxes as standard are made with a male connection spigot with a gasket ( $d_1$ ) - e.g. PLX-PLO-75-2-100. The female connection spigot ( $d_1$ ) will be marked with the letter – F in the product code, e.g. FLX-PLO-90-1-125-F

Semi-rigid ducting

# FLX-HDPE/FLX-HDPE-A



## Description

FLX-HDPE and FLX-HDPE-A plastic ducts are used to air distribution in domestic ventilation systems. Relatively small diameters allow to hide the installation in ceilings, screeds or suspended ceilings. FLX-HDPE and FLX-HDPE-A semi-rigid ducts are connected to other system components like plenum boxes or distribution boxes with a simple push fit connection. Application of seals on the FLX-PLO plenum boxes' spigots guarantees high air tightness system.

FLX-HDPE and FLX-HDPE-A semi-rigid ducting is made of high-impact polyethylene. This makes the entire ventilation ductwork very durable.

FLX-HDPE-A ducts are complying with European norm **EN 17192:2018** for ridged or semi-rigid non-metallic ductwork, which defines the test methods and performance characteristics like airtightness, pressure drop, reaction to fire, resistance to external pressure, thermal resistance and microbial resistance.

The semi-rigid ducting is delivered in 50-metre long coils.

### Dimensions of the coil:

FLX-HDPE-A-50: 1200cm x 40cm

FLX-HDPE-A-63: 1200cm x 40cm

FLX-HDPE-75/FLX-HDPE-A-75: 1100cm x 40cm

FLX-HDPE-90/FLX-HDPE-A-90: 1400cm x 50cm

### Product code example

Product code: **FLX - HDPE - 75**

type \_\_\_\_\_  
 material \_\_\_\_\_  
 diameter \_\_\_\_\_

## Dimensions

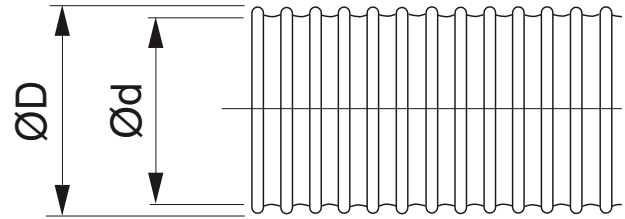

Product code	$\phi D$ [mm]	$\phi d$ [mm]	Bend radius [m]	Weight [kg]
FLX-HDPE-A-50	50	41	0.23	0.23
FLX-HDPE-A-63	63	51	0.26	0.26
FLX-HDPE-75	75	63	0.29	0.31
FLX-HDPE-A-75	75	63	0.29	0.31
FLX-HDPE-90	90	75	0.33	0.42
FLX-HDPE-A-90	90	75	0.33	0.42

Semi-rigid ducting

# FLX-HDPE/FLX-HDPE-A

## Technical data

Pressure drop for 75 and 90mm ducts, straight section L=1m



\* greater pressure drop for higher airflow for 90mm duct occurs because of its curved inner structure

Pressure drop for FLX-HDPE-A-90 duct with various bend radiuses 15-90° L=1,5m

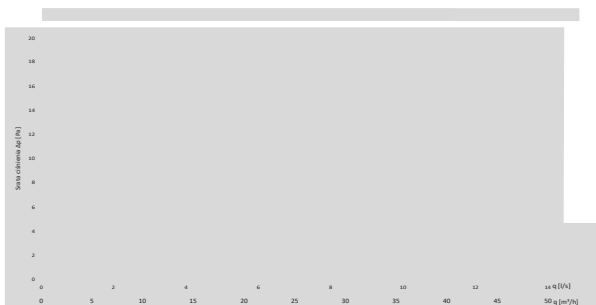

Pressure drop for FLX-HDPE-A-75 duct with various bend radiuses 15-90° L=1,5m

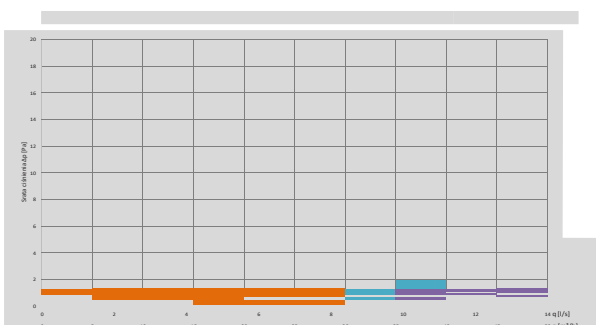

Characteristics of the product according to EN 17192:2018

Air tightness class	ATC 3 (old C)	EN 12237
Service temperature	STL -20°C to STH +100°C	EN 17192:2019-01
Reaction to fire class	E	EN 13501-1
Resistance to external pressure	DN63mm: 343 N DN75mm: 394 N DN90mm: 366 N	EN 17192:2019-01
Thermal resistance	$\lambda \cdot m = 0,3900$ W/(m·k)	EN 12664:2002
Microbial resistance	R = 2,9	EN ISO 22196:2011

Plenum box for air valve

# FLX-PLO/FLX-PRO



## Description

FLX-PLO / FLX-PRO plenum boxes are components of the FLX-REKU system intended for domestic mechanical ventilation systems, also known as mechanical ventilation heat recovery (MVHR) or heat recovery ventilation.

The low profile plenum boxes require less installation space than standard solutions, which is very convenient when they should not be prominent once concealed. This advantage helps free up usable indoor area.

FLX-PLO plenum boxes are made of galvanized steel sheet.

Plenum boxes made from stainless steel are available on request.

Available also insulated plenum box version - **FLX-PLI** and **FLX-PRI**. These plenum boxes have inside a insulation lining made from 9 mm thick rubber foam.

FLX-PLO plenum boxes are equipped with duct connection spigot  $\varnothing d_2$  with a EPDM seal – this type of connection with FLX-HDPE ducting is airtight and easy to install.

### Product code example

Product code **FLX-PLO - 75 - 2 - 150 - F**

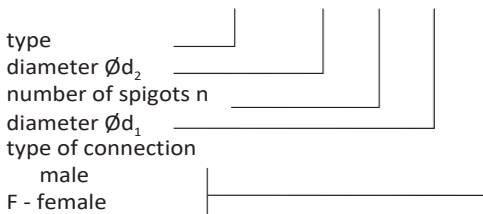

## Dimensions

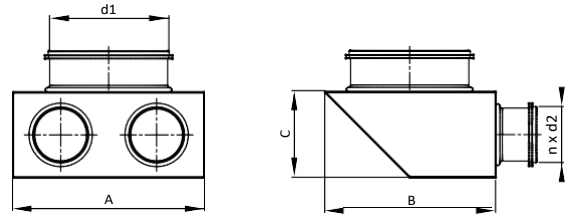

Product code	A [mm]	B [mm]	C [mm]	$d_1$ [mm]	n [szt.]	$d_2$ [mm]
FLX-PRO-63-1- $d_1$	180	180	75	80-160	1	63
FLX-PRO-63-2- $d_1$	180	180	75	80-160	2	63
FLX-PRO-63-3- $d_1$	180	270	75	80-160	3	63
FLX-PLO-75-1- $d_1$	180	200	90	80-160	1	63
FLX-PLO-75-2- $d_1$	180	200	90	80-160	2	63
FLX-PLO-75-3- $d_1$	180	300	90	80-160	3	63
FLX-PLO-90-1- $d_1$	180	200	90	80-160	1	75
FLX-PLO-90-2- $d_1$	180	200	90	80-160	2	75
FLX-PLO-90-3- $d_1$	180	300	90	80-160	3	75

Duct connection spigot  $d_1$ : 80, 100, 125, 150, 160 mm

**FLX-CS-PVC** end caps fit connection spigots of FLX-PLO-75 and FLX-PLO-90 plenum boxes.

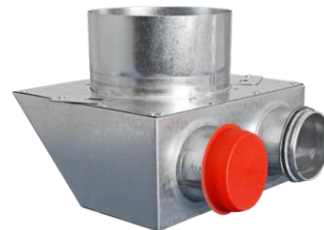

**FLX-CF-PVC** end caps fit (inside) duct connection spigots of FLX-PRO-63 plenum boxes.



Plenum box for air valve

# FLX-PLO/FLX-PRO

## Technical data

Pressure drop charts for the supply air plenum box:  $\varnothing 100, \varnothing 125$

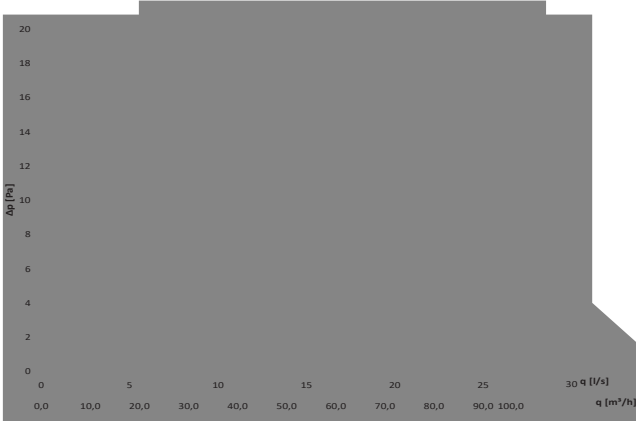

Pressure drop charts for the exhaust air plenum box:  $\varnothing 100, \varnothing 125$

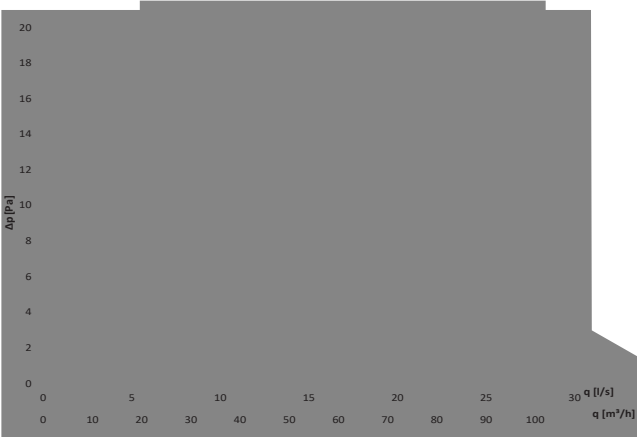

## Types of plenum boxes

FLX-PLO plenum box



FLX-PRO plenum box (spigot - 63mm only)



FLX-PLO-75-2-160 male connection spigot  $\varnothing d_1$  with a seal



FLX-PLO-75-2-160-F female connection spigot  $\varnothing d_1$

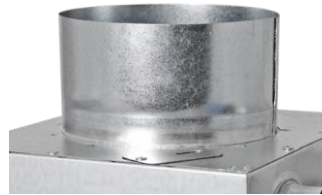

On request, plenum boxes can be supplied with additional safety clips, that secure the semi-rigid duct in the place and protect it from disconnecting: FLX-PLO-75-...-H



# Plenum boxes with long connection spigot for air valve

## FLX-PLO-L / FLX-PRO-L



### Description

FLX-PLO-L / FLX-PRO-L plenum boxes with long connection spigot are components of the FLX-REKU system intended for domestic mechanical ventilations systems, also known as mechanical ventilation heat recovery (MVHR) or heat recovery ventilation. The low profile plenum boxes require less installation space than standard solutions, which is very convenient when they should not be prominent once concealed. This advantage helps free up usable indoor area.

FLX-PLO-L / FLX-PRO-L plenum boxes are made of galvanized steel sheet. Plenum boxes made from stainless steel are available on request.

Available also insulated plenum box version - FLX-PLI-L / FLX-PRI-L. These plenum boxes have inside a insulation lining made from 9 mm thick rubber foam.

FLX-PLO-L plenum boxes are equipped with duct connection spigot  $\varnothing d_2$  with a EPDM seal – this type of connection with FLX-HDPE ducting is airtight and easy to install.

#### Product code example

Product code **FLX-PLO-L - 75 - 2 - 150 - F**

type  
 diameter  $\varnothing d_2$   
 number of spigots n  
 diameter  $\varnothing d_1$   
 type of connection  
 male  
 F - female

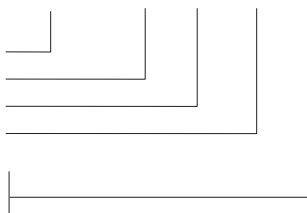

### Dimensions

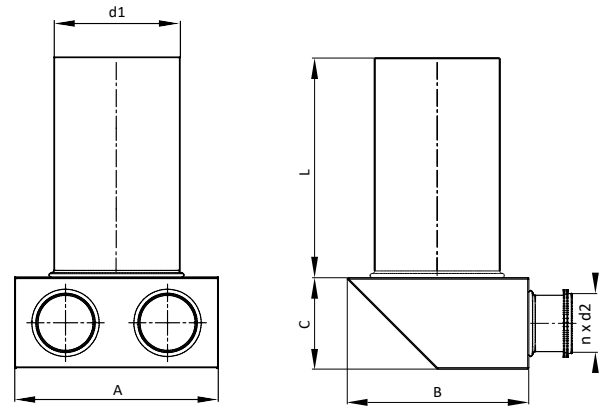

Product code	A [mm]	B [mm]	C [mm]	L [mm]	$d_1$ [mm]	n [pcs.]	$d_2$ [mm]
FLX-PRO-L-63-1- $d_1$	180	180	75	320	80-160	1	63
FLX-PRO-L-63-2- $d_1$	180	180	75	320	80-160	2	63
FLX-PRO-L-63-3- $d_1$	180	270	75	320	80-160	3	63
FLX-PLO-L-75-1- $d_1$	180	200	90	320	80-160	1	63
FLX-PLO-L-75-2- $d_1$	180	200	90	320	80-160	2	63
FLX-PLO-L-75-3- $d_1$	180	300	90	320	80-160	3	63
FLX-PLO-L-90-1- $d_1$	180	200	90	320	80-160	1	75
FLX-PLO-L-90-2- $d_1$	180	200	90	320	80-160	2	75
FLX-PLO-L-90-3- $d_1$	180	300	90	320	80-160	3	75

Duct connection spigot  $d_1$ : 80, 100, 125, 150, 160 mm

**FLX-CS-PVC** end caps fit connection spigots of FLX-PLO-75 and FLX-PLO-90 plenum boxes.



**FLX-CF-PVC** end caps fit (inside) duct connection spigots of FLX-PRO-63 plenum boxes.





Plenum boxes with long connection spigot for air valve

# FLX-PLO-L / FLX-PRO-L

## Types of plenum boxes

FLX-PLO plenum box



FLX-PRO plenum box (spigot - 63mm only)



FLX-PLO-75-2-160 male connection spigot  $\varnothing d_1$  with a seal



FLX-PLO-75-2-160-F female connection spigot  $\varnothing d_1$

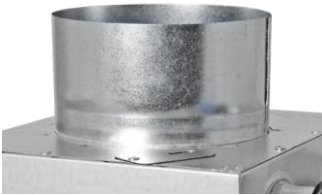

On request, plenum boxes can be supplied with additional safety clips, that secure these semi-rigid duct in the place and protect it from disconnecting: FLX-PLO-75-...-H



## How to install



# FLX-SRGL-320



## Description

FLX-SRGL-320 is an extension piece made of longitudinal seam welded plain pipe in 320mm length. The extension piece is applied for FLX-PLO, FLX-PRO, FLX-PLO-P and FLX-PRO-P plenum boxes and used as an extension of the spigot  $\varnothing d_1$  for a supply/ exhaust air valve, e.g. equal to slab thickness.

### Product code example

Product code **FLX-SRGL - 100 - 320**



## Dimensions

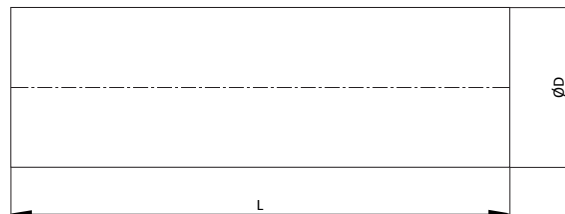

Product code	Diameter $\varnothing D$ [mm]	Length L [mm]
FLX-SRGL-080-0032	80	320
FLX-SRGL-100-0032	100	320
FLX-SRGL-125-0032	125	320
FLX-SRGL-140-0032	140	320
FLX-SRGL-150-0032	150	320
FLX-SRGL-160-0032	160	320
FLX-SRGL-180-0032	180	320
FLX-SRGL-200-0032	200	320

## How to install



# Plenum boxes for grilles

## FLX-PLO-MOV



### Description

The FLX-MOV plenum box is used for mounting supply-exhaust grilles in the residential ventilation system with heat recovery unit. The plenum box has on the one end male duct connection spigot for FLX-HDPE ducts, and on the other end it has a slot adapted to SHR grilles.

In addition, the height (length) of the plenum box is adjustable in the range of 200-310, which allows you to match the plenum box size to the partition thickness.

#### Product code example

Product code **FLX-PLO-MOV - 75 - 2**



### Dimensions

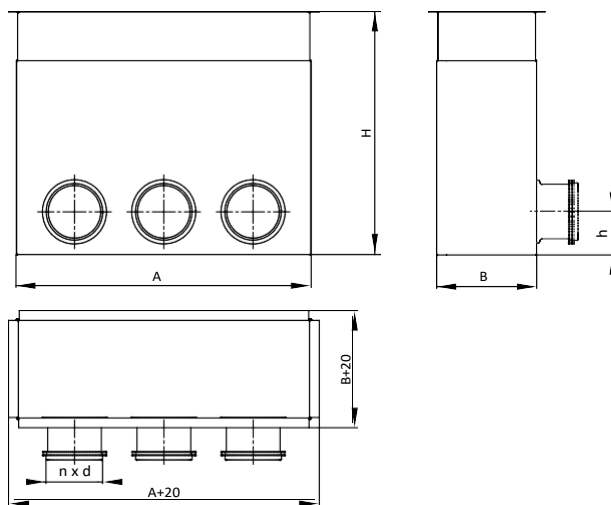

Product code	SHR	A [mm]	B [mm]	H [mm]	d [mm]	h [mm]	n [pcs]
FLX-PLO-MOV-75-2	200x100	204	103	200-310	63	44	2
FLX-PLO-MOV-75-3	300x100	304	103	200-310	63	44	3

### How to install



## Distribution box for FLX-REKU system

# FLX-PLO-R / FLX-PRO-R



### Description

The FLX-PLO-R / FLX-PRO-R distribution boxes (manifolds) are used to run the domestic ventilation ductwork to each individual room. As a rule, one air distribution box with a proper amount of FLX duct connection spigots is installed in the supply and exhaust stair. However, the number of air distribution boxes depends on the building design. The  $\varnothing d_1$  connection spigot is used to connect the main supply or exhaust duct from the heat recovery unit. FLX-HDPE / FLX-HDPE-A ducting is connected to  $\varnothing d_2$  connection spigots.

FLX-PLO-R / FLX-PRO-R distribution boxes are made of galvanized steel sheet. Air distribution boxes made from stainless steel are available on request.

Available also insulated distribution box version - FLX-PLI-R / FLX-PRI-R. These distribution boxes have inside a insulation lining made from 9 mm thick rubber foam.

FLX-PLO-R distribution boxes are equipped with duct connection spigots  $\varnothing d_2$  with an EPDM seal – this type of connection with FLX-HDPE ducting is airtight and easy to install.

#### Product code example

Product code: **FLX-PLO-R - 75 - 2-4-2-0 - 160 - F**



### Dimensions

An example of a technical drawing of FLX-PLO-R-75-3-5-3-5-d1 distribution box

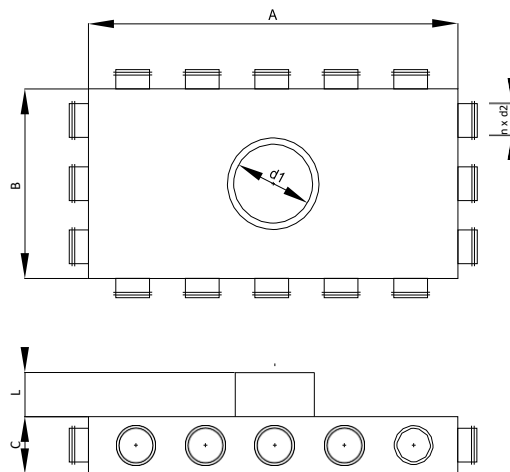

Product code	A [mm]	B [mm]	C [mm]	L [mm]	$d_1$ [mm]	n [pcs.]	$d_2$ [mm]
FLX-PRO-R-63-2-4-2-0-d1	360	180	75	60	80-250	8	63
FLX-PRO-R-63-0-3-0-3-d1	270	270	75	60	80-250	6	63
FLX-PRO-R-63-0-4-0-4-d1	360	360	75	60	80-250	8	63
FLX-PRO-R-63-3-6-3-0-d1	540	270	75	60	80-250	12	63
FLX-PRO-R-63-0-5-0-5-d1	450	450	75	60	80-250	10	63
FLX-PRO-R-63-0-7-0-7-d1	630	280	75	60	80-250	14	63
FLX-PRO-R-63-3-5-3-5-d1	450	270	75	60	80-250	16	63
FLX-PRO-R-63-3-6-3-6-d1	540	270	75	60	80-250	18	63
FLX-PLO-R-75-2-4-2-0-d1	400	200	90	60	80-250	8	63
FLX-PLO-R-75-0-3-0-3-d1	300	300	90	60	80-250	6	63
FLX-PLO-R-75-0-4-0-4-d1	400	300	90	60	80-250	8	63
FLX-PLO-R-75-3-6-3-0-d1	600	300	90	60	80-250	12	63
FLX-PLO-R-75-0-5-0-5-d1	500	300	90	60	80-250	10	63
FLX-PLO-R-75-0-7-0-7-d1	700	300	90	60	80-250	14	63
FLX-PLO-R-75-3-5-3-5-d1	500	300	90	60	80-250	16	63
FLX-PLO-R-75-3-6-3-6-d1	600	300	90	60	80-250	18	63
FLX-PLO-R-90-2-4-2-0-d1	400	200	90	60	80-250	8	75
FLX-PLO-R-90-0-3-0-3-d1	300	300	90	60	80-250	6	75
FLX-PLO-R-90-0-4-0-4-d1	400	300	90	60	80-250	8	75
FLX-PLO-R-90-3-6-3-0-d1	600	300	90	60	80-250	12	75
FLX-PLO-R-90-0-5-0-5-d1	500	300	90	60	80-250	10	75
FLX-PLO-R-90-0-7-0-7-d1	700	300	90	60	80-250	14	75
FLX-PLO-R-90-3-5-3-5-d1	500	300	90	60	80-250	16	75
FLX-PLO-R-90-3-6-3-6-d1	600	300	90	60	80-250	18	75



# FLX-PLO-R / FLX-PRO-R

## How to order

Product code: FLX-PLO-R- $\varnothing d_2$ -1-2-3-4- $\varnothing d_1$

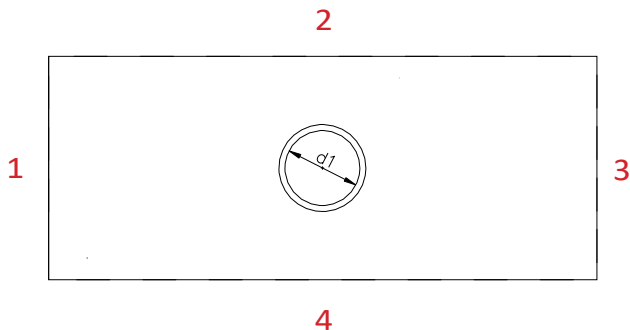

where:

- type FLX-PLO
- $\varnothing d_2$  FLX-HDPE-50 duct connection spigot ( $\varnothing 50$  mm)
- 1-2-3-4 number and configuration of connection spigots
- $\varnothing d_1$  80,100,125,150,160,180,200,250 mm SPIRAL duct diameter
- Z no connection spigots, DIY solution = cutting at the construction site
- F female connection / no symbol = male connection

### Choose distribution box according to number of spigots:

FLX-HDPE $\varnothing$ [mm]	No. of FLX duct connection spigots n [pcs.]	Product code of distribution box
63	6	FLX-PRO-R-63-0-3-0-3-d1
	8	FLX-PRO-R-63-2-4-2-0-d1
	8	FLX-PRO-R-63-0-4-0-4-d1
	9	FLX-PRO-R-63-3-6-3-0-d1
	10	FLX-PRO-R-63-0-5-0-5-d1
	14	FLX-PRO-R-63-0-7-0-7-d1
	16	FLX-PRO-R-63-3-5-3-5-d1
	18	FLX-PRO-R-63-3-6-3-6-d1
75	6	FLX-PLO-R-75-0-3-0-3-d1
	8	FLX-PLO-R-75-2-4-2-0-d1
	8	FLX-PLO-R-75-0-4-0-4-d1
	9	FLX-PLO-R-75-3-6-3-0-d1
	10	FLX-PLO-R-75-0-5-0-5-d1
	14	FLX-PLO-R-75-0-7-0-7-d1
	16	FLX-PLO-R-75-3-5-3-5-d1
	18	FLX-PLO-R-75-3-6-3-6-d1
90	6	FLX-PLO-R-90-0-3-0-3-d1
	8	FLX-PLO-R-90-2-4-2-0-d1
	8	FLX-PLO-R-90-0-4-0-4-d1
	9	FLX-PLO-R-90-3-6-3-0-d1
	10	FLX-PLO-R-90-0-5-0-5-d1
	14	FLX-PLO-R-90-0-7-0-7-d1
	16	FLX-PLO-R-90-3-5-3-5-d1
	18	FLX-PLO-R-90-3-6-3-6-d1

## Types of plenum boxes

FLX-PLO plenum box

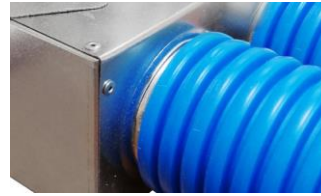

FLX-PRO plenum box (spigot - 63mm only)



FLX-PLO-75-2-160 male connection spigot  $\varnothing d_1$  with a seal



FLX-PLO-75-2-160-F female connection spigot  $\varnothing d_1$



On request, plenum boxes can be supplied with additional safety clips, that secure the semi-rigid duct in the place and protect it from disconnecting: FLX-PLO-75-...-H



Distribution box for FLX-REKU system

# FLX-PLO-R / FLX-PRO-R

## Technical data

Pressure drop charts for supply air distribution boxes:

**FLX-PLO-R-75-3-0-3-0-d1**

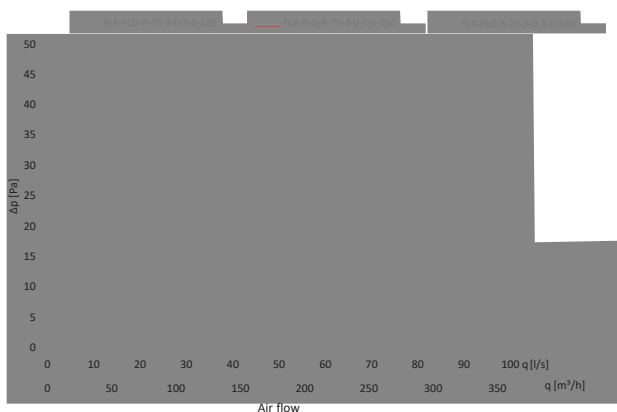

**FLX-PLO-R-75-4-0-4-0-d1**

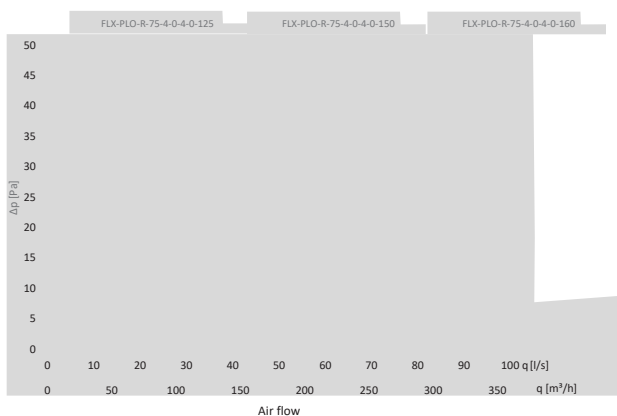

**FLX-PLO-R-75-5-0-5-0-d1**

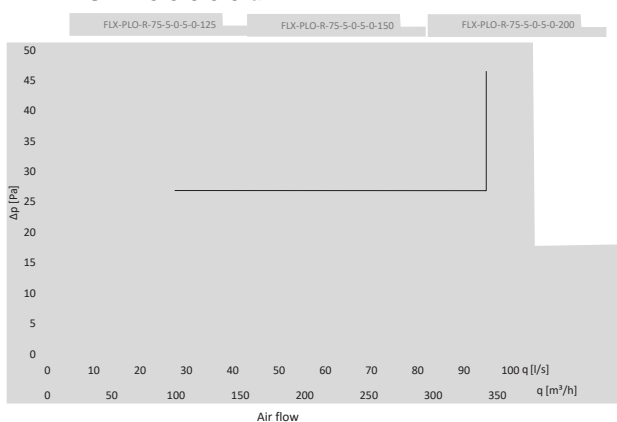

Pressure drop charts for exhaust air distribution boxes:

**FLX-PLO-R-75-3-0-3-0-d1**



**FLX-PLO-R-75-4-0-4-0-d1**

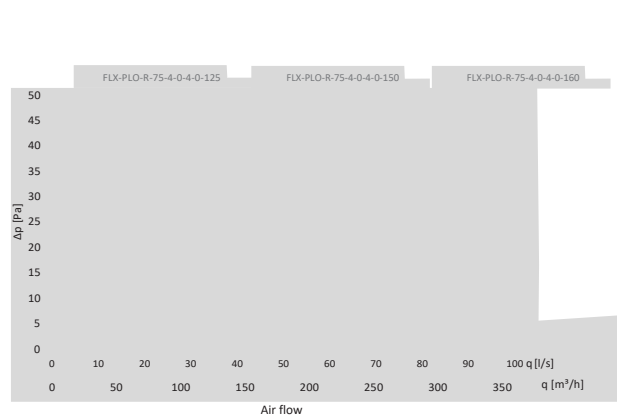

**FLX-PLO-R-75-5-0-5-0-d1**

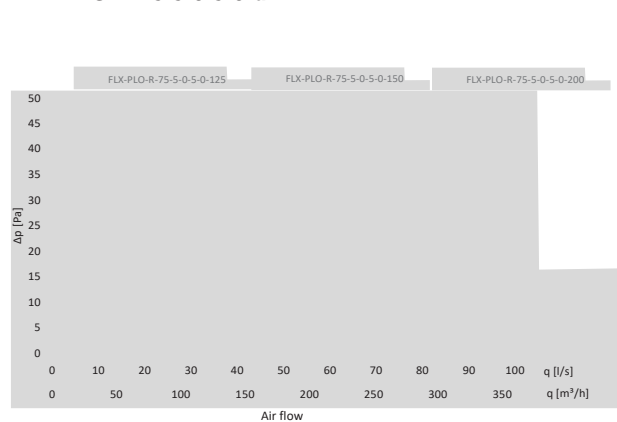

# FLX-PLO-R / FLX-PRO-R

## Technical data

Pressure drop charts for supply air distribution boxes:

**FLX-PLO-R-75-7-0-7-0-d1**

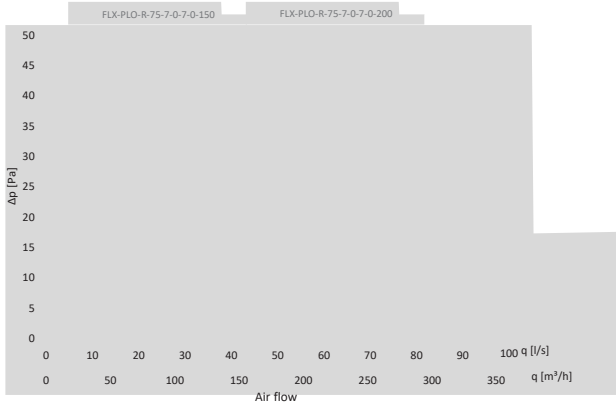

Pressure drop charts for exhaust air distribution boxes:

**FLX-PLO-R-75-7-0-7-0-d1**

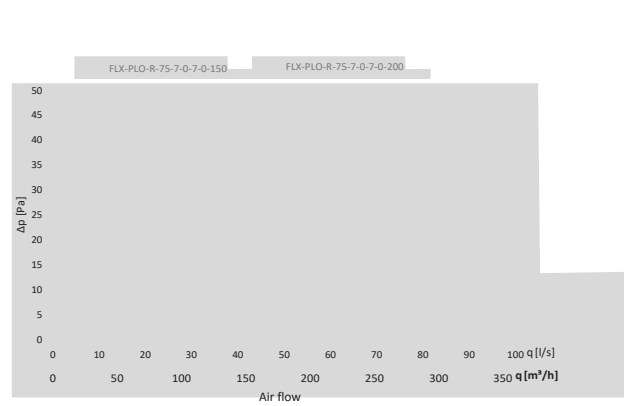

**FLX-PLO-R-75-2-4-2-0-d1**

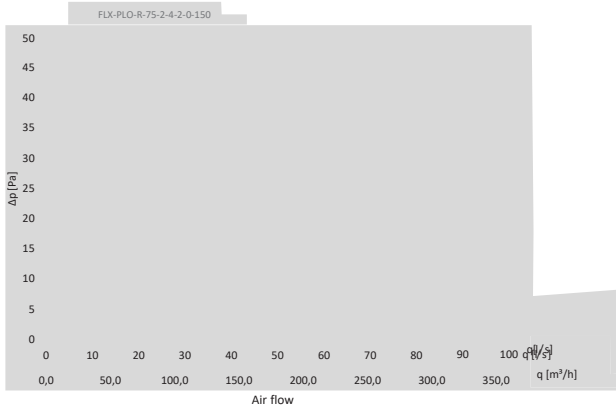

**FLX-PLO-R-75-2-4-2-0-d1**

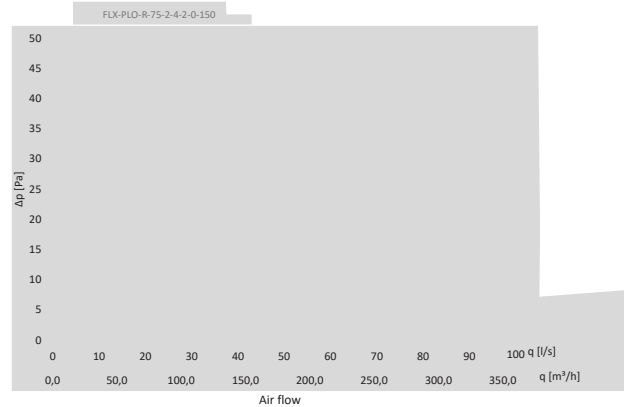

**FLX-PLO-R-75-0-8-0-0-150-F-L / FLX-PLO-R-75-0-12-0-0-150-F-L**

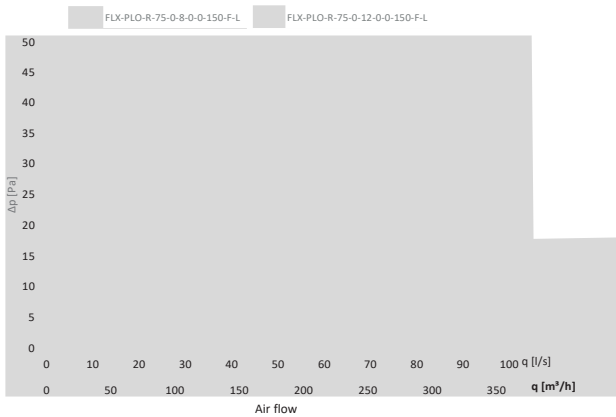

**FLX-PLO-R-75-0-8-0-0-150-F-L / FLX-PLO-R-75-0-12-0-0-150-F-L**

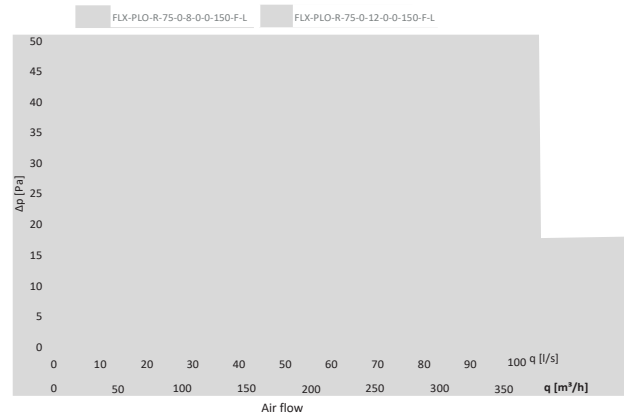



Horizontal plenum box for air valve

# FLX-PLO-PL / FLX-PRO-PL



## Description

FLX-PLO-P / FLX-PRO-P plenum boxes are components of the FLX-REKUsystemintendedfordomesticmechanicalventilation systems, also known as mechanical ventilation heat recovery (MVHR) or heat recovery ventilation. In this plenum box type, spigots  $\varnothing d_1$  and  $\varnothing d_2$  are aligned on single side.

The low profile plenum boxes require less installation space than standard solutions, which is very convenient when they should not be prominent once concealed. This advantage helps free up usable indoor area.

FLX-PLO-PL/ FLX-PRO-PLplenum boxes aremadeofgalvanized steel sheet. Plenum boxes made from stainless steel are available on request.

Available also insulated plenum box version - **FLX-PLI-PL/ FLX-PRI-PL**. These plenum boxes have inside a insulation lining made from 9 mm thick rubber foam.

FLX-PLO-PL plenum boxes are equipped with duct connection spigot  $\varnothing d_2$  with an EPDM seal – this type of connection with FLX-HDPE ducting is airtight and easy to install.

### Product code example

Product code: **FLX-PLO-PL - 75 - 2 - 150 - F**

type

diameter  $\varnothing d_2$

number of spigots n

diameter  $\varnothing d_1$

type of connection

male

F - female

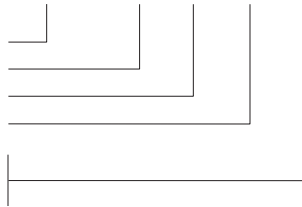

## Dimensions

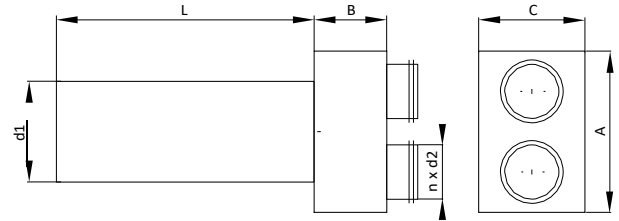

Product code	A [mm]	B [mm]	C [mm]	L [mm]	$d_1$ [mm]	n [pcs.]	$d_2$ [mm]
FLX-PRO-PL-63-2- $d_1$	180	90	200	320	80-160	2	63
FLX-PRO-PL-63-3- $d_1$	180	90	300	320	80-160	3	63
FLX-PLO-PL-75-2- $d_1$	220	90	220	320	125	2	75
FLX-PLO-PL-75-2- $d_1$	220	90	220	320	160	2	75
EX-PLO-PL-75-2- $d_1$	250	90	250	320	200	2	75
FLX-PLO-PL-75-3- $d_1$	320	90	220	320	125	3	75
FLX-PLO-PL-75-3- $d_1$	320	90	220	320	160	3	75
FLX-PLO-PL-75-3- $d_1$	320	90	250	320	200	3	75
EX-PLO-PL-90-2- $d_1$	250	90	250	320	125	2	90
FLX-PLO-PL-90-2- $d_1$	250	90	250	320	160	2	90
FLX-PLO-PL-90-2- $d_1$	250	90	250	320	200	2	90
EX-PLO-PL-90-3- $d_1$	370	90	250	320	125	3	90
FLX-PLO-PL-90-3- $d_1$	370	90	250	320	160	3	90
FLX-PLO-PL-90-3- $d_1$	370	90	250	320	200	3	90

**FLX-CS-PVC** end caps fit connection spigots of FLX-PLO-75 and FLX-PLO-90 plenum boxes.



**FLX-CF-PVC** end caps fit (inside) duct connection spigots of FLX-PRO-63 plenum boxes.



Horizontal plenum box for air valve

# FLX-PLO-PL / FLX-PRO-PL

## *Types of plenum boxes*

FLX-PLO plenum box



FLX-PRO plenum box (spigot - 63mm only)



FLX-PLO-75-2-160 male connection spigot  $\varnothing d_1$  with a seal

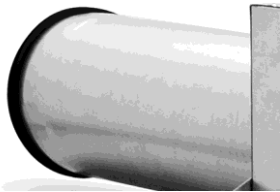

FLX-PLO-75-2-160-F female connection spigot  $\varnothing d_1$



On request, plenum boxes can be supplied with additional safety clips, that secure the semi-rigid duct in the place and protect it from disconnecting: FLX-PLO-75-...-H



## Horizontal distribution box for FLX-REKU system

# FLX-PLO-R-P



### Description

The FLX-PLO-R-P / FLX-PRO-R-P distribution boxes (manifolds) are used to run the domestic ventilation ductwork to each individual room. The air distribution box is equipped with a perforated panel, which is intended for even airflow distribution. As a rule, one air distribution box with a proper amount of FLX duct connection spigots is installed in the supply and exhaust stair. However, the number of air distribution boxes depends on the building design. The  $\varnothing d_1$  connection spigot is used to connect the main supply or exhaust duct from the heat recovery unit. FLX-HDPE / FLX-HDPE-A ducting is connected to  $\varnothing d_2$  connection spigots.

FLX-PLO-R-P / FLX-PRO-R-P distribution boxes are made of galvanized steel sheet. Air distribution boxes made from stainless steel are available on request.

Available also insulated distribution box version - FLX-PLI-R-P / FLX-PRI-R-P. These distribution boxes have inside a insulation lining made from 9 mm thick rubber foam.

FLX-PLO-R-P distribution boxes are equipped with duct connection spigots  $\varnothing d_2$  with a EPDM seal – this type of connection with FLX-HDPE ducting is airtight and easy to install.



FLX-CF-PVC end caps fit duct connection spigots  $\varnothing d_2$  of FLX-PLO-R-P and FLX-PRO-R-P distribution boxes.

#### Product code example

Product code **FLX-PRO-R-P - 75 - 2x10 - 200 -**

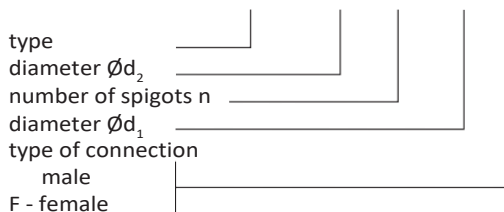

### Dimensions

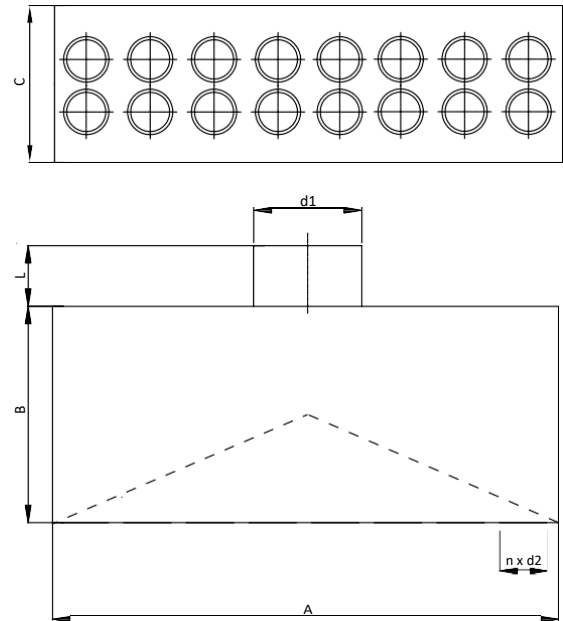

Product code	A [mm]	B [mm]	C [mm]	L [mm]	$d_1$ [mm]	n [pcs.]	$d_2$ [mm]
FLX-PRO-R-P-63-2x5-d1	500	180	230	60	80-250	10	63
FLX-PRO-R-P-63-2x6-d1	600	180	230	60	80-250	12	63
FLX-PRO-R-P-63-2x7-d1	700	180	230	60	80-250	14	63
FLX-PLO-R-P-75-2x5-d1	500	180	230	60	80-250	10	63
FLX-PLO-R-P-75-2x6-d1	600	180	230	60	80-250	12	63
FLX-PLO-R-P-75-2x7-d1	700	180	230	60	80-250	14	63
FLX-PLO-R-P-90-2x5-d1	500	180	230	60	80-250	10	75
FLX-PLO-R-P-90-2x6-d1	600	180	230	60	80-250	12	75
FLX-PLO-R-P-90-2x7-d1	700	180	230	60	80-250	14	75

Duct connection spigot  $d_1$ : 80, 100, 125, 150, 160, 180, 200, 250 mm.

#### Choose distribution box according to number of spigots:

FLX-HDPE $\varnothing$ [mm]	No of FLX duct connection spigots n [pcs.]	Product code of distribution box
63	10	FLX-PRO-R-P-63-2x5-d1
	12	FLX-PRO-R-P-63-2x6-d1
	14	FLX-PRO-R-P-63-2x7-d1
75	10	FLX-PLO-R-P-75-2x5-d1
	12	FLX-PLO-R-P-75-2x6-d1
	14	FLX-PLO-R-P-75-2x7-d1
90	10	FLX-PLO-R-P-90-2x5-d1
	12	FLX-PLO-R-P-90-2x6-d1
	14	FLX-PLO-R-P-90-2x7-d1

# FLX-PLO-R-P

## Technical data

Pressure drop charts for supply air distribution boxes:

FLX-PLO-R-P-75-2x5-d1

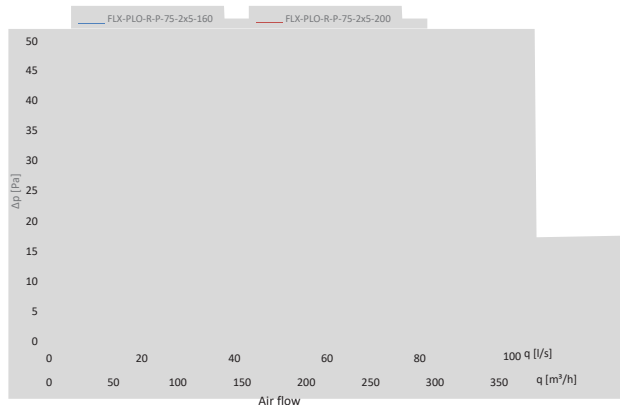

Pressure drop charts for exhaust air distribution boxes:

FLX-PLO-R-P-75-2x5-d1

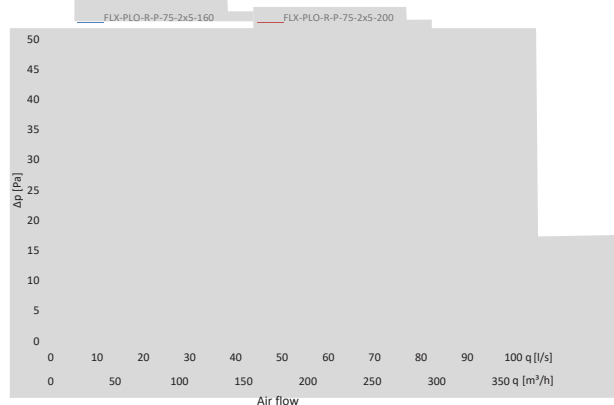

Silencer for heat recovery ventilation system

# FLX-SQOL



## Description

The FLX-SQOL silencer was designed as an attenuating element that is mounted before the FLX-PLO / FLX-PRO plenum box. It has either 1 or 2 spigots (just like the number of FLX-PLO / FLX-PRO plenum boxes spigots), the silencer is connected using FLX-HDPE ducting. In the case of 3-spigot FLX-PLO plenum boxes, it's recommended to use a combination of two silencers -  $2n + 1n$ . The FLX-SQOL silencer are insulated with an attenuating material - non-combustible stone wool.

### Product code example

Product code: **FLX-SQOL - 75 - 1 - 300**

type \_\_\_\_\_

diameter \_\_\_\_\_

number of spigots \_\_\_\_\_

length \_\_\_\_\_

## Dimensions

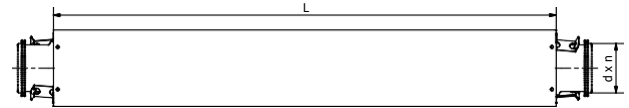
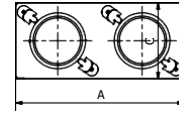

Product code	A [mm]	C [mm]	L [mm]	d [mm]	No of spigots n [pcs.]
FLX-SQOL-75-1-300	120	90	300	63	1
FLX-SQOL-75-1-600	120	90	600	63	1
FLX-SQOL-75-1-900	120	90	900	63	1
FLX-SQOL-75-2-300	200	90	300	63	2
FLX-SQOL-75-2-600	200	90	600	63	2
FLX-SQOL-75-2-900	200	90	900	63	2
FLX-SQOL-90-1-300	120	110	300	75	1
FLX-SQOL-90-1-600	120	110	600	75	1
FLX-SQOL-90-1-900	120	110	900	75	1
FLX-SQOL-90-2-300	240	110	300	75	2
FLX-SQOL-90-2-600	240	110	600	75	2
FLX-SQOL-90-2-900	240	110	900	75	2

# FLX-ODSQL



## Dimensions

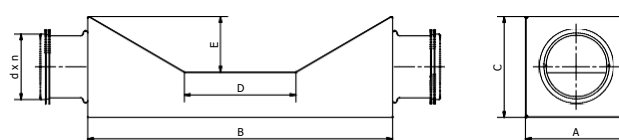

## Description

FLX-ODSQL offset plenum boxes are components of the FLX-REKU system which are used to intersect two main ventilation ducts or to lead ducts over other installations in the floor. Offset plenum boxes with 1 or 2 FLX-HDPE duct connector spigots with a diameter of 75 and 90 mm are available.

FLX-ODSQL-75-1-300 can be crossed with three FLX-ODSQL-75-1-100 plenum boxes - the width of the maximum clearance allows to bypass upto 3 plenumboxes-  $3 \times 90\text{mm}$  (dimension A)  $< 300\text{ mm}$  (dimension D).

### Product code example

Product code: **FLX-ODSQL - 75 - 1 - 300**



Product code	A [mm]	B [mm]	C [mm]	D [mm]	E [mm]	$\phi d$ [mm]	No of spigots n [pcs.]
FLX-ODSQL-75-1-100	90	275	90	100	50	63	1
FLX-ODSQL-75-1-300	90	475	90	300	50	63	1
FLX-ODSQL-75-2-100	200	275	90	100	50	63	2
FLX-ODSQL-75-2-300	200	475	90	300	50	63	2
FLX-ODSQL-90-1-120	110	310	110	120	60	75	1
FLX-ODSQL-90-1-370	110	50	110	370	60	75	1
FLX-ODSQL-90-2-120	240	310	110	120	60	75	2
FLX-ODSQL-90-2-370	240	550	110	370	60	75	2

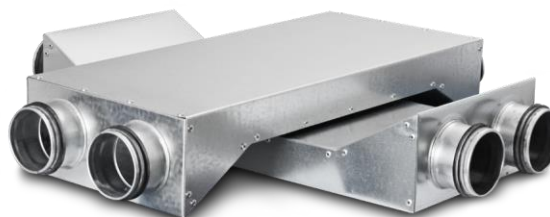

Pressed bends

# FLX-BP



## Description

FLX-BP pressed ventilation bends are used with the FLX-HDPE/FLX-HDPE-A semi-rigid ducting. The bend is made by seam welding for improved installation airtightness. The duct is connected by inserting it into the bend. The pressed form of the ventilation bend helps to reduce the airflow resistance and the pressure loss. The air tightness class can be increased to class B by wrapping the joints with the TAL, MET or DUCT sealing tape.

### Available materials — Product code example

FLX-BP-090-90-... - galvanized steel sheet

### Product code example

Product code: **FLX-BP - aaa - 90**

type	_____
Ød <sub>1</sub>	_____
°	_____

## Dimensions

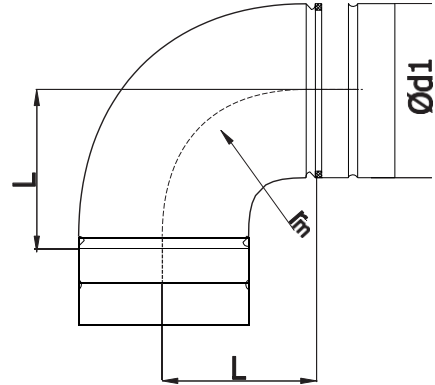

$$r_m \approx 1 \times d_1$$

Product code	Ød <sub>1</sub> [mm]	L [mm]
FLX-BP-075-90	75	100
FLX-BP-090-90	90	100

# Short reducers for ventilation systems

## FLX-RPC/FLX-RSCL



### Description

FLX-RPC/FLX-RSCL reducers are used with the FLX-HDPE/FLX-HDPE-A semi-rigid ducting. The reducer is made by seam welding for improved installation airtightness. The duct is connected by inserting it into the reducer. The air tightness class can be increased to class B by wrapping the joints with the TAL, MET or DUCT sealing tape.

#### Available materials — Product code example

FLX-RPC-...-... - galvanized steel sheet  
 FLX-RSCL-...-... - galvanized steel sheet

#### Product code example

Product code: **FLX-RPC - aaa - bbb**

type \_\_\_\_\_  
 $\varnothing d_1$  \_\_\_\_\_  
 $\varnothing d_2$  \_\_\_\_\_

### Dimensions

FLX-RPC

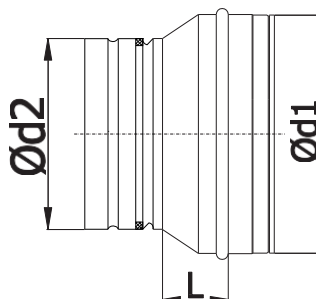

FLX-RSCL

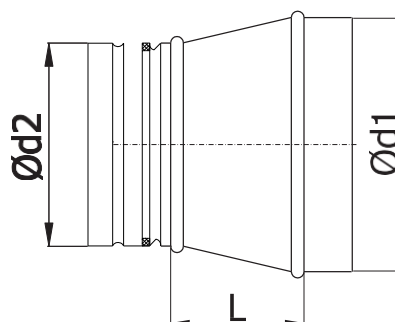

Product code	$\varnothing_{1\text{ nom}}$ [mm]	$\varnothing_{2\text{ nom}}$ [mm]	L [mm]	Weight [kg]
FLX-RPC-100-075	100	75	18	0.20
FLX-RPC-125-075	125	75	28	0.20
FLX-RPC-160-075	160	75	34	0.24
FLX-RSCL-100-090	100	90	47	0.19
FLX-RSCL-125-090	125	90	74	0.24
FLX-RSCL-160-090	160	90	113	0.35



Reducer/ transition piece for SPIRAL system and FLX-REKU system

# FLX-RSFCLL



## Description

FLX-RSFCLL reducer is used as a transition piece between SPIRAL system ductwork and FLX-REKU system ducting. On the one end it has male connection in diameters: 100-160mm (for SPIRAL duct), on the other end it has male connection in diameter 75 or 90mm for FLX-HDPE ducting.

### Product code example

Product code:: **FLX-RSFCLL - 100 - 75**

type \_\_\_\_\_  
 diameter  $\varnothing d_1$  \_\_\_\_\_  
 diameter  $\varnothing d_2$  \_\_\_\_\_

## Dimensions

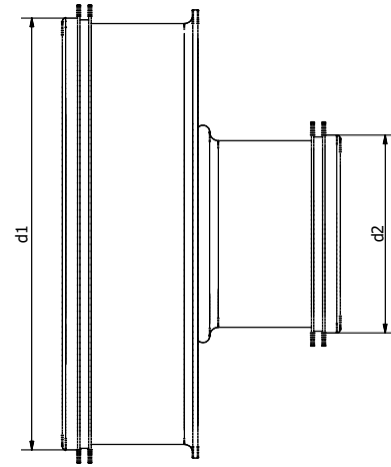

Product code	$d_1$ [mm]	$d_2$ [mm]
FLX-RSFCLL-100-75	100	63
FLX-RSFCLL-125-75	125	63
FLX-RSFCLL-160-75	160	63
FLX-RSFCLL-100-90	100	75
FLX-RSFCLL-125-90	125	75
FLX-RSFCLL-160-90	160	75

# FLX-SP



## Description

FLX-SP pressed collar saddle is used to join SPIRAL ductwork and FLX-REKU ducting.

### Available materials — Product code example

FLX-SP-... -... - galvanized steel sheet

### Product code example

Product code:: **FLX-SP - aaa - bbb**

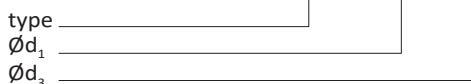

## Dimensions

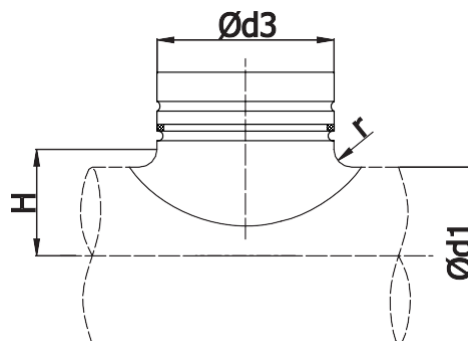

Product code	$\varnothing d_{1\text{nom}} - \varnothing d_{3\text{nom}}$ [mm]	diameter range for $\varnothing d_{1\text{nom}}$ [mm]	r [mm]	H [mm]	Weight [kg]
FLX-SP-100-75	100-75	100 - 112	10	60	0,1
FLX-SP-125-75	125-75	112 - 125 - 140	10	72	0,1
FLX-SP-160-75	160-75	150 - 160	10	90	0,1
FLX-SP-200-75	200-75	180 - 200	10	110	0,1
FLX-SP-250-75	250-75	224 - 250 - 280 300 - 315	10	135	0,1

# Shut-off dampers

## FLX-DAS



### Description

FLX-DAS shut-off dampers are a good choice when the ductwork closure does not have to be fully airtight. This product is rather intended for regulation of the airflow. The damper closure angle is between 0 and 90°.

The FLX-DAS shutoff dampers are made from galvanized steel sheet. Available also damper version made from stainless steel on special request.

#### Product code example

Product code: **FLX-DAS - 75**

type \_\_\_\_\_  
 $\varnothing d_1$  \_\_\_\_\_

### Dimensions

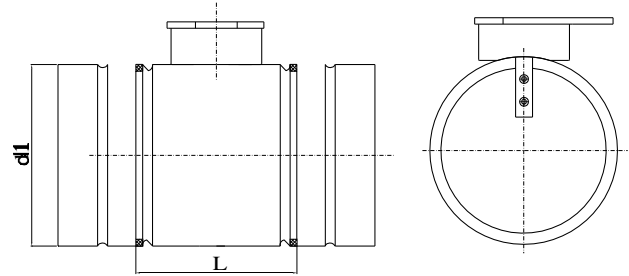

Product code	$d_1$ [mm]	L [mm]
FLX-DAS-75	75	110
FLX-DAS-90	90	110

Airtight shut-off dampers

# FLX-DAT



## Description

FLX-DAT dampers are a good choice when the ductwork closure must be airtight. The damper is used for cutting off the airflow. The damper closure angle is between 0 and 90°. The FLX-DAT airtight, shutoff dampers are made from galvanized steel sheet. Available also damper version made from stainless steel on special request.

### Product code example

Product code:

**FLX-DAT - 75**

type \_\_\_\_\_

Ød<sub>1</sub> \_\_\_\_\_

## Dimensions

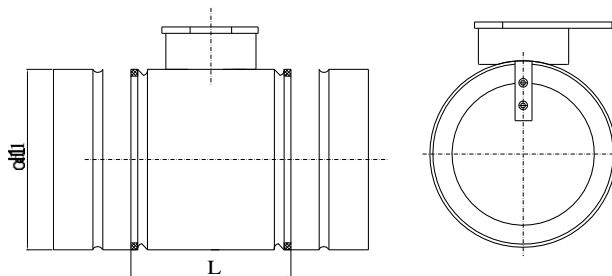

Product code	d <sub>1</sub> [mm]	L [mm]
FLX-DAT-75	75	110
FLX-DAT-90	90	110

Male coupling for FLX-REKU system

# FLX-NSL



## Description

The FLX-NSL male coupling is intended for the joining FLX-HDPE and FLX-HDPE-A semi-rigid ducting. The male coupling has factory installed EPDM rubber seals, which guarantee an airtight connection.

### Product code example

Product code: **FLX-NSL - 75**

type \_\_\_\_\_  
diameter \_\_\_\_\_

## Dimensions

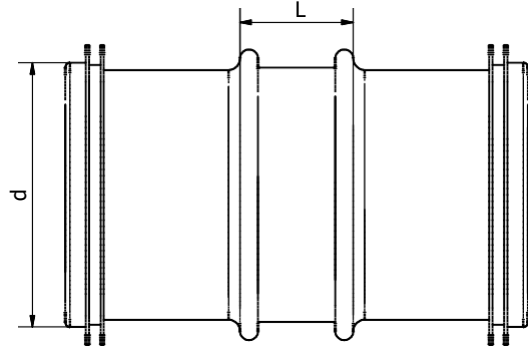

Product code	d [mm]	L [mm]
FLX-NSL-75	63	25
FLX-NSL-90	75	25

## How to install



# Female couplings FLX-MSF...



## Description

FLX-MSF female couplings are designed for joining sections of FLX-HDPE or FLX-HDPE-A ducting. In order to achieve airtightness class C acc. EN 12237, it's recommended to use EPDM seals - FLX-USZ.

### Product code example

Product code: **FLX-MSF - 75**

type \_\_\_\_\_  
 $\varnothing d_1$  \_\_\_\_\_

## Dimensions

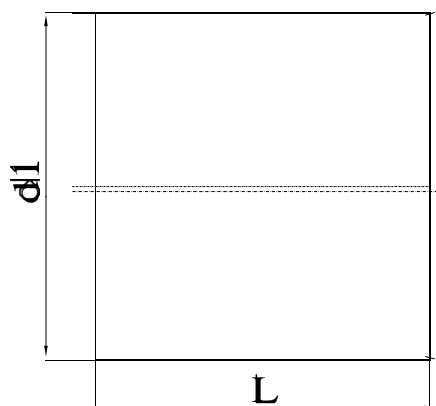

Product code	$d_1$ [mm]	L [mm]
FLX-MSF-63	63	100
FLX-MSF-75	75	100
FLX-MSF-90	90	100

# Seal rings for FLX ducting FLX-USZ...



## Description

FLX-USZ-63/FLX-USZ-75/FLX-USZ-90 seal rings are made of EPDM and provide sealing at the connection between ducts and female couplings which meet the airtightness class C as per EN 12237.

FLX-USP-63/FLX-USP-75/FLX-USP-90 gaskets are made of foam and installed inside the connection spigots of plenum boxes and dampers. The gaskets are used to seal the connection between plenum boxes and semi-rigid ducting - meet the air tightness class B as per EN 12237.

FLX-UST-63/FLX-UST-75/FLX-UST-90 heat-shrink gaskets for connecting and sealing the joints between two ducts or a duct and a plenum box.

### Product code example

Product code: **FLX-USZ - 75**

type \_\_\_\_\_  
 $\varnothing d_1$  \_\_\_\_\_

## Dimensions

FLX-USZ-63 / FLX-USZ-75 /  
FLX-USZ-90

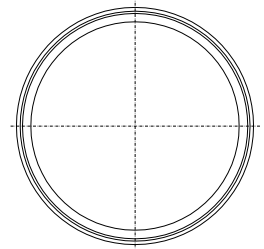
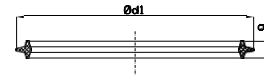

FLX-USP-63 / FLX-USP-75 /  
FLX-USP-90

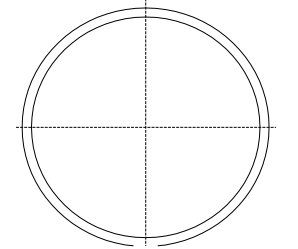
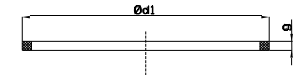

FLX-UST-63 / FLX-UST-75 /  
FLX-UST-90

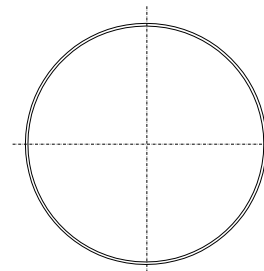
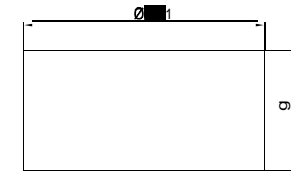

Product code	$\varnothing d_1$ [mm]	$g$ [mm]
FLX-USZ-63	65	8
FLX-USP-63	63	6
FLX-UST-63	63	100
FLX-USZ-75	78	8
FLX-USP-75	75	6
FLX-UST-75	75	100
FLX-USZ-90	93	8
FLX-USP-90	90	6
FLX-UST-90	90	100

# Fastening support FLX-FAX...



## Description

FLX-FAX fastening supports facilitate routing and fastening of semi-rigid ducting at 90°. The fastening supports keep the installed duct firmly in place to prevent shifting when casting concrete floors over the ductwork.

The FLX-FAX fastening supports are made from galvanized steel sheet.

Special versions made from stainless steel are available on request.

### Product code example

Product code: **FLX-FAX - 75 - 2**

type

$\varnothing d_1$

number of ducts

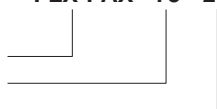

## Dimensions

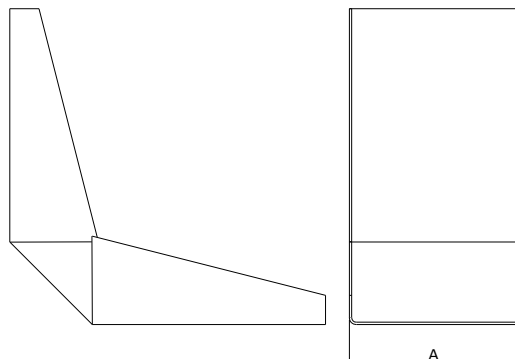

Product code	A [mm]
FLX-FAX-63	68
FLX-FAX-63-2	131
FLX-FAX-75	80
FLX-FAX-75-2	155
FLX-FAX-90	95
FLX-FAX-90-2	190



End caps

# FLX-CS-PVC/FLX-CF-PVC



## Description

The FLX-CS-PVC end cap is used for plugging the ends of FLX-HDPE and FLX-HDPE-A ducts, e.g. when installing ducting on the construction site - they effectively protect against contamination of the interior of the ducts. At the same time, FLX-CS-PVC end cap is also used to plug unused connection spigots in plenum boxes and FLX-PLO distribution boxes (but they are not inserted inside the spigot, but onto it).

FLX-CF-PVC end caps are used for plugging unused connection spigots in plenum boxes and FLX-PRO distribution boxes. The end caps are made of PVC.

### Product code example

Product code: **FLX-CS-PVC - 75**

type   
diameter

## Dimensions

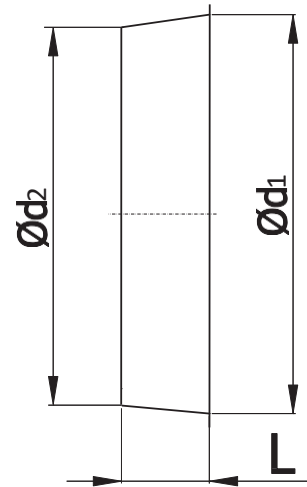

Product code	$\varnothing_1$ [mm]	$\varnothing_2$ [mm]	L [mm]
FLX-CS-PVC-63	51	49	20
FLX-CF-PVC-63	66	63	20
FLX-CS-PVC-75	63	59	20
FLX-CF-PVC-75	78	78	20
FLX-CS-PVC-90	76	74	20
FLX-CF-PVC-90	95	91	20

## How to install



**FLX-CS-PVC** end caps fit inside FLX-HDPE and FLX-HDPE-A ducting.



**FLX-CS-PVC** end caps are mounted onto the connection spigots of FLX-PLO-75 and FLX-PLO-90 plenum boxes.



**FLX-CF-PVC** end caps fit inside the connection spigots of FLX-PRO-63 plenum boxes.

# Plenum box for air valve

## FLX-PLO-50



### Description

The FLX-PLO-50 plenum boxes for air valve are the lowest plenum boxes available in FLX-REKU system. Due to their small dimensions, these plenum boxes do not require much installation space, which is very convenient when they should not be prominent once concealed. This advantage helps free up usable indoor area. One side of the plenum box is cut off and plays the role of a steering wheel - the air stream is immediately redirected to the ventilation ducts. FLX-PLO-50 plenum boxes are made of galvanized steel as a standard. Plenum boxes made from stainless steel are available on request.

#### Product code example

Product code **FLX-PLO - 50 - 4 - 150 -**

type  
 diameter  $\varnothing d_2$   
 number of spigots  $n$   
 duct diameter  $\varnothing d_1$   
 type of connection  
 male  
 F - female

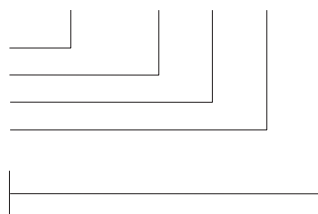

### Dimensions

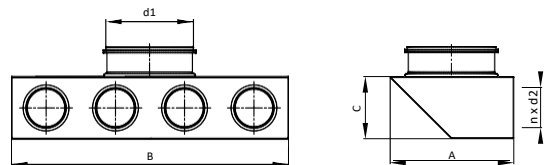

Product code	A [mm]	B [mm]	C [mm]	$d_1$ [mm]	n [pcs.]	$d_2$ [mm]
FLX-PLO-50-2- $d_1$	180	200	75	80-160	2	50
FLX-PLO-50-3- $d_1$	180	300	75	80-160	3	50
FLX-PLO-50-4- $d_1$	180	400	75	80-160	4	50

Duct connection spigot  $d_1$ : 80, 100, 125, 150, 160 mm

### How to install



Plenum boxes with long connection spigot for air valve

# FLX-PLO-L-50



## Description

FLX-PLO-L-50 plenum boxes with long connection spigot are the lowest plenum boxes available in FLX-REKU System. Due to their small dimensions, these plenum boxes do not require much installation space, which is very convenient when they should not be prominent once concealed. This advantage helps free up usable indoor area. Plenum boxes are ideal solution for ventilation systems with heat recovery.

FLX-PLO-L-50 plenum boxes are made of galvanized steel sheet. Plenum boxes made from stainless steel are available on request.

### Product code example

Product code **FLX-PLO-L - 50 - 3 - 150 -**

type	_____
diameter $\varnothing d_2$	_____
number of spigots n	_____
duct diameter $\varnothing d_1$	_____
type of connection	_____
male	_____
F - female	_____

## Dimensions

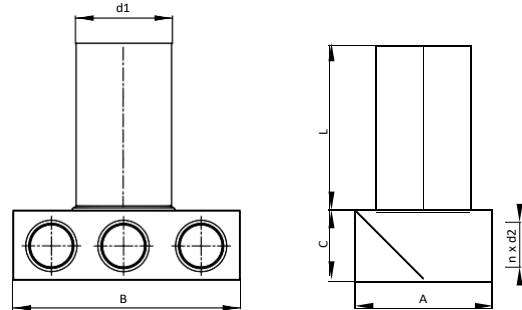

Product code	A [mm]	B [mm]	C [mm]	L [mm]	$d_1$ [mm]	n [pcs.]	$d_2$ [mm]
FLX-PLO-L-50-2- $d_1$	180	200	75	320	80-160	2	50
FLX-PLO-L-50-3- $d_1$	180	300	75	320	80-160	3	50
EX-PLO-L-50-4- $d_1$	180	400	75	320	80-160	4	50

Duct connection spigot  $d_1$ : 80, 100, 125, 150, 160 mm

## How to install



# FLX-PLO-R-50



## Description

FLX-PLO-R-50 distribution boxes (manifold) are used to run the domestic ventilation ductwork to each individual room. As a rule, one distribution box is installed in the supply and exhaust air with the correct number of spigots for FLX-HDPE ducting. However, the building design specifics may require more distribution boxes. The  $\varnothing d_1$  duct connection spigot is used to connect the main supply or exhaust air duct from the heat recovery unit. FLX-HDPE / FLXHDPE-A ducting is connected to  $\varnothing d_2$  connection spigots. FLX-PLO-R-50 distribution boxes are made of galvanized steel sheet. Air distribution boxes made from stainless steel are available on request.

### Product code example

Product code: **FLX-PLO-R-50-4-8-4-8-160-**

type  
 diameter  $\varnothing d_2$   
 number of spigots  
 duct diameter  $\varnothing d_1$   
 type of connection  
 male  
 F - female

## Dimensions

An example of a technical drawing of FLX-PLO-R-50-4-8-4-8-d1 distribution box

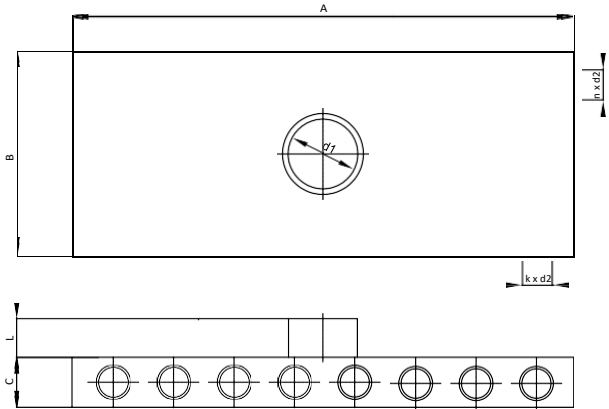

Product code	A [mm]	B [mm]	C [mm]	L [mm]	d <sub>1</sub> [mm]	n [pcs.]	d <sub>2</sub> [mm]
FLX-PLO-R-50-0-7-0-7-d1	700	300	75	60	80-250	14	50
FLX-PLO-R-50-3-5-3-5-d1	500	300	75	60	80-250	16	50
FLX-PLO-R-50-3-6-3-6-d1	600	300	75	60	80-250	18	50
FLX-PLO-R-50-4-8-4-8-d1	800	400	75	60	80-250	24	50

Duct connection spigot d<sub>1</sub>: 80, 100, 125, 150, 160, 180, 200, 250 mm

### Choose distribution box according to number of spigots:

FLX-HDPE $\varnothing$ [mm]	No. of FLX duct connection spigots n [pcs.]	Product code of distribution box
50	14	FLX-PLO-R-50-0-7-0-7-d1
	16	FLX-PLO-R-50-3-5-3-5-d1
	18	FLX-PLO-R-50-3-6-3-6-d1
	24	FLX-PLO-R-50-4-8-4-8-d1

## How to order

Product code: FLX-PLO-R- $\varnothing d_2$ -1-2-3-4- $\varnothing d_1$

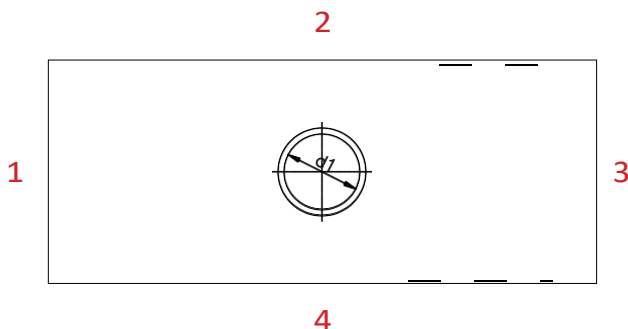

where:

- type FLX-PLO
- $\varnothing d_2$  FLX-HDPE-50 duct connection spigot ( $\varnothing 50$  mm)
- 1-2-3-4 number and configuration of connection spigots  $\varnothing d_1$   
80,100,125,150,160,180,200,250 mm SPIRAL duct diameter
- Z no connection spigots, DIY solution = cutting at the construction site
- F female connection / no symbol = male connection

Horizontal distribution box for FLX-REKU system

**FLX-PLO-R-P-50****Description**

FLX-PLO-R-P-50 distribution boxes (manifolds) are used to run the domestic ventilation ductwork to each individual room. The air distribution box is equipped with a perforated panel, which is intended for even airflow distribution.

As a rule, one air distribution box with a proper amount of FLX-HDPE duct connection spigots is installed in the supply and exhaust air. However, the number of air distribution boxes depends on the building design. The  $\varnothing d_1$  connection spigot is used to connect the main supply or exhaust duct from the heat recovery unit. FLX-HDPE / FLX-HDPE-A ducting is connected to  $\varnothing d_2$  connection spigots.

FLX-PLO-R-P-50 distribution boxes are made of galvanized steel sheet. Air distribution boxes made from stainless steel are available on request

**Product code example**

Product code **FLX-PLO-R-P - 50 - 2x8 - 200 -**

type  
 diameter  $\varnothing d_2$   
 number of spigots n  
 diameter  $\varnothing d_1$   
 type of connection  
 male  
 F - female

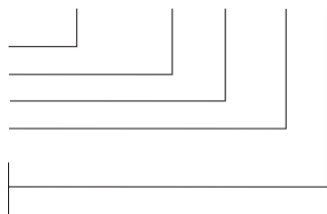
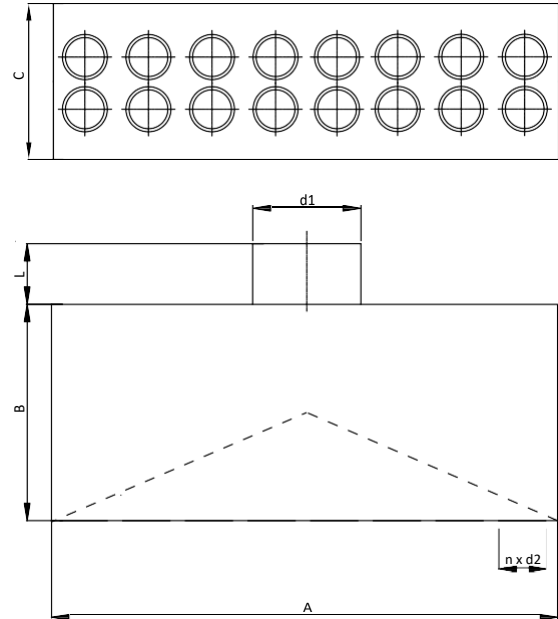
**Dimensions**

Product code	A [mm]	B [mm]	C [mm]	L [mm]	$d_1$ [mm]	n [pcs.]	$d_2$ [mm]
FLX-PRO-R-P-50-2x6-d1	600	180	230	60	80-250	12	50
FLX-PLO-R-P-50-2x8-d1	800	180	230	60	80-250	16	50
FLX-PLO-R-P-50-2x10-d1	1000	180	230	60	80-250	20	50
FLX-PLO-R-P-50-2x12-d1	1200	180	230	60	80-250	24	50

Duct connection spigot  $d_1$ : 80, 100, 125, 150, 160, 180, 200, 250 mm.

**Choose distribution box according to number of spigots:**

FLX-HDPE $\varnothing$ [mm]	No. of FLX duct connection spigots n [pcs.]	Product code of distribution box
50	12	FLX-PLO-R-P-50-2x6-d1
	16	FLX-PLO-R-P-50-2x8-d1
	20	FLX-PLO-R-P-50-2x10-d1
	24	FLX-PLO-R-P-50-2x12-d1

# FLX-HDPE-132-52

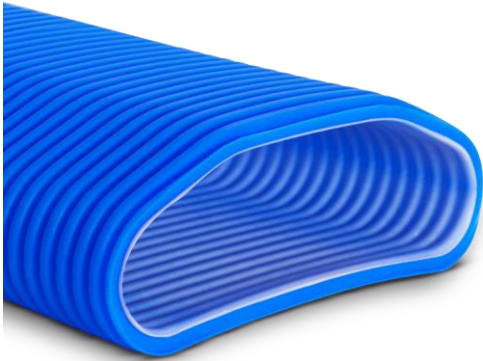

## Description

FLX-HDPE-132-52 semi-rigid, oval ducts are intended for ventilation systems in single-family housing projects. FLX-HDPE-132-52 is made of HDPE (high-density polyethylene), a material with crush resistant construction and flexible enough for easy ductwork routing. The 20-metre sections help minimize the number of joints to improve the overall installation airtightness. This is a perfect duct for air distribution in single-family home ventilation systems laid on concrete floors within home insulation voids. The semi-rigid, oval ducting, plenum boxes and fittings make a perfect MHRV system with heat recovery unit. The ducts are joined with the plenum box by fitting onto the male connection ends.



FLX-CS-PVC-132-52 end cap is used for fitting inside the duct, e.g. during the ductwork installation on the construction site - it effectively protects against contamination of the interior of the ducts.

**Mechanical compressive strength:** 450 N

**Antibacterial coating** as per ISO 22196:2007  
Effective against: Staphylococcus aureus, Escherichia coli

**Lifetime of the antibacterial coating:** 30 years

**Temperature resistance:** combustible; softening point at 130°C, flash point at 350°C, class B2.

### Product code example

Product code: **FLX - HDPE - 132-52**

type \_\_\_\_\_  
material \_\_\_\_\_  
dimension \_\_\_\_\_

## Dimensions

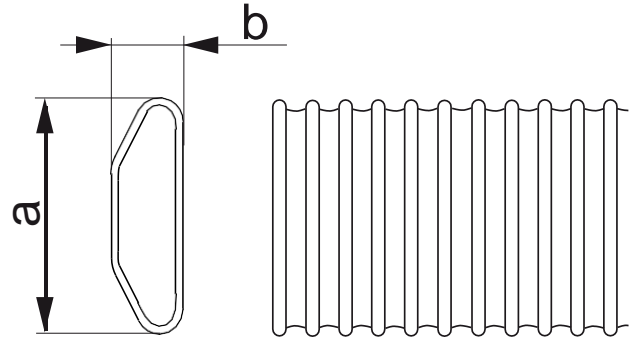

Product code	a [mm]	b [mm]	a <sub>wewn</sub> [mm]	b <sub>wewn</sub> [mm]	Bending radius [cm]	
					vertical	horizontal
FLX-HDPE-132-52	132	52	122	38	15	30

## Technical data

Pressure loss chart for 1-metre long duct

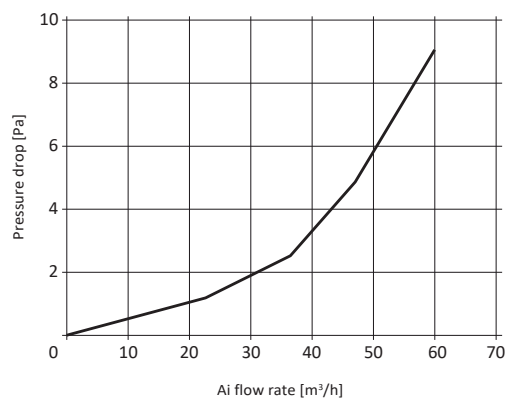

# Metal plenum box for air supply and exhaust valves FLX-PRV-...-1-F / FLX-PRV-...-2-F

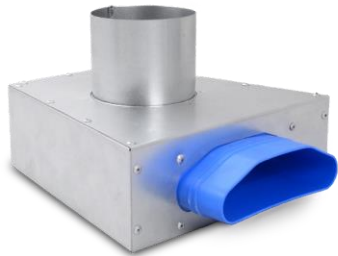

## Description

FLX-PRV-...-1-F / FLX-PRV-...-2-F plenum boxes are used for air supply and exhaust valves. The plenum boxes are made from galvanized steel sheet, and plastic oval duct connection spigots that are designed to fit the FLX-HDPE-132-52 semi-rigid oval ducts. The plenum boxes are available with 1 or 2 oval connection spigots and SPIRAL duct connection spigots in diameter: 80 / 110 / 125 mm. Thanks to the low profile of the plenum box, it saves space and is perfect for concealing with cast-in-place concrete.

**Available versions:** code example FLX-PRV- $\varnothing d_1$ -n-F-O  
 FLX-PRV-125-1 male connection spigot  $\varnothing d_1$   
 FLX-PRV-125-1-F female connection spigot  $\varnothing d_1$   
 FLX-PRV-125-1-O male connection spigot  $\varnothing d_1$ ,  
 the spigot inverted by 180°

where:  
 $\varnothing d_1$  - air valve diameter: 80 / 100 / 125 mm  
 n - number of FLX-HDPE132-52 duct connection spigots

### Product code example

Product code: **FLX-PRV - 100 - 1 - F -**

type \_\_\_\_\_  
 diameter  $\varnothing d_1$  \_\_\_\_\_  
 number of spigots \_\_\_\_\_  
 type of connection \_\_\_\_\_  
     male \_\_\_\_\_  
 F - female \_\_\_\_\_  
 O - inverted spigot \_\_\_\_\_

## Dimensions

FLX-PRV-1-...-F

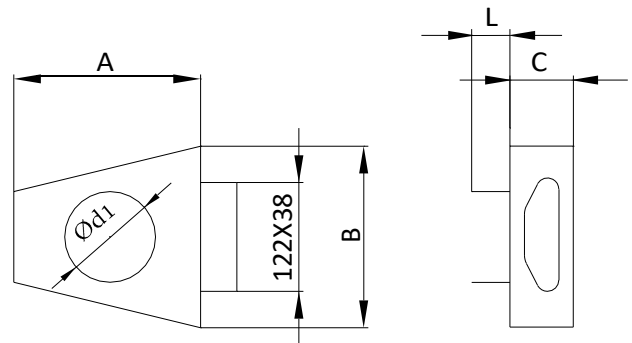

FLX-PRV-2-...-F

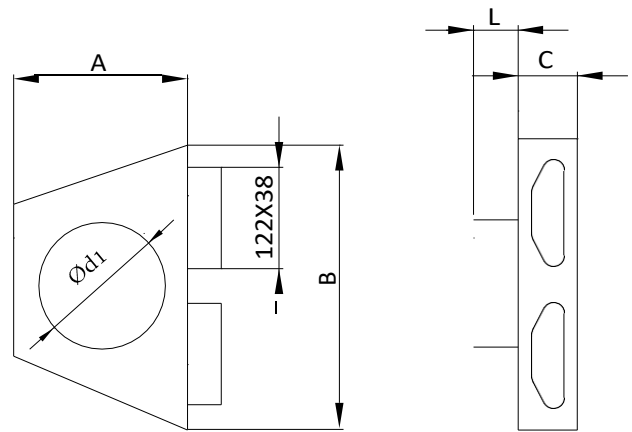

Product code	A [mm]	B [mm]	C [mm]	L [mm]	$\varnothing d_1$ [mm]	n [pcs.]
FLX-PRV-080-1	200	200	70	320	80	1
FLX-PRV-100-1	200	200	70	320	100	1
FLX-PRV-125-1	200	200	70	320	125	1
FLX-PRV-080-2	300	300	70	320	80	2
FLX-PRV-100-2	300	300	70	320	100	2
FLX-PRV-125-2	300	300	70	320	125	2

Metal plenum box for air supply and exhaust valves

# FLX-PRV-...-1-1

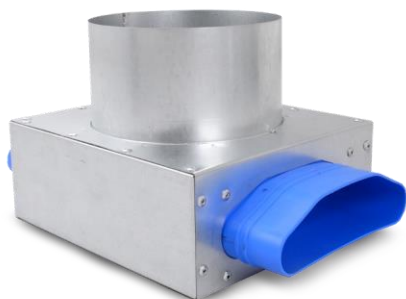

## Description

FLX-PRV-...-1-1 plenum boxes for air valves, with oval connection spigots designed to fit HDPE-132-52 ducting. In this plenum box version 2 oval spigots are installed on the opposite sides of the plenum box.

**Available versions:** example FLX-PRV- $\varnothing d_1$ -1-1-F-O  
 FLX-PRV-125-1-1 male connection spigot  $\varnothing d_1$   
 FLX-PRV-125-1-1-F female connection spigot  $\varnothing d_1$   
 FLX-PRV-125-1-1-O male connection  $\varnothing d_1$ ,  
 the spigot inverted by 180°

where:

$\varnothing d_1$  - air valve diameter 100 / 125 mm

### Product code example

Product code: **FLX-PRV - 125 - 1-1 - F -**

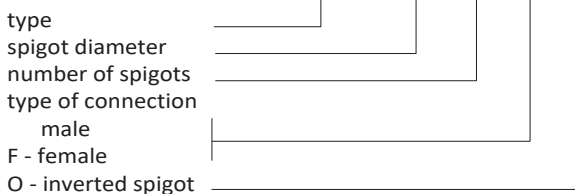

## Dimensions

FLX-PRV-1-...-F

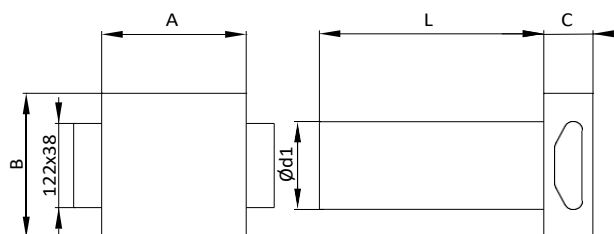

Product code	A [mm]	B [mm]	C [mm]	L [mm]	$\varnothing d_1$ [mm]
FLX-PRV-125-1-1	180	160	70	320	125



# FLX-PRV-R

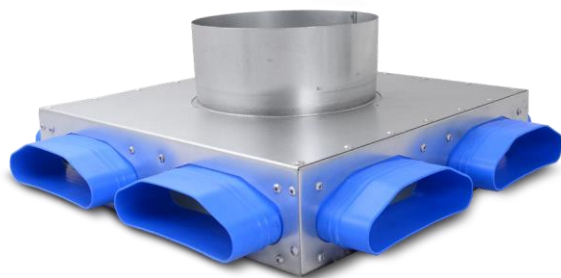

## Description

FLX-PRV-R distribution box (manifold) is designed for installation in concrete screed or insulation layer, the distribution box has oval connection spigots that fit FLX-HDPE-132-52 ducting. Depending on the spigot configuration, the distribution box has from 2 to 8 spigots.

### Note:

The connection spigot  $d_1$  is male in the standard version. The diameter  $d_1$  is available as a female connection on request, simply add "F" to the product code.

### Product code example

Product code: **FLX-PRV-R-2-2-2-2-160-F**

type  
number of spigots  
spigot diameter  $\varnothing d_1$   
type of connection  
male  
F - female

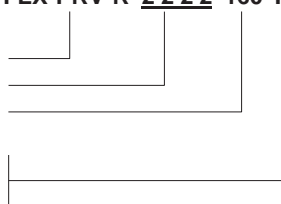

## Dimensions

FLX-PRV-R-2-2-0-0-160

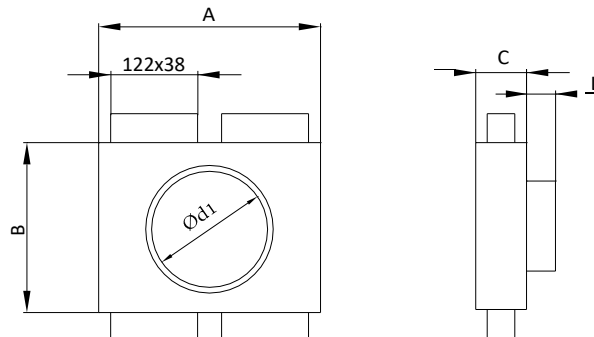

Product code	Number of spigots n [pcs.]	$\varnothing d_1$ [mm]	A [mm]	B [mm]	C [mm]	L [mm]
FLX-PRV-R-2-2-2-2-160	8	160	300	300	70	40
FLX-PRV-R-2-2-2-2-200	8	200	300	300	70	40
FLX-PRV-R-2-2-2-0-160	6	160	300	300	70	40
FLX-PRV-R-2-2-2-0-200	6	200	300	300	70	40
FLX-PRV-R-0-2-2-0-160	4	160	300	300	70	40
FLX-PRV-R-0-2-2-0-200	4	200	300	300	70	40
FLX-PRV-R-2-0-2-0-160	4	160	300	200	70	40
FLX-PRV-R-2-0-2-0-200	4	200	300	200	70	40
FLX-PRV-R-2-0-0-0-160	2	160	300	200	70	40
FLX-PRV-R-2-0-0-0-200	2	200	300	200	70	40

How to order: FLX-PLV-R-1-2-3-4- $\varnothing d_1$

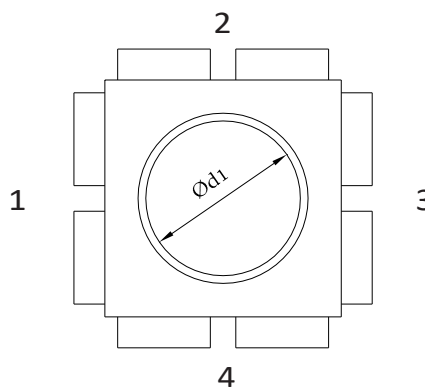

### Note!

- 1-2-3-4 number and configuration of duct connection spigots that fit FLX-HDPE-132-52 ducting
- Diameter  $\varnothing d_1$  is 160 mm or 200 mm
- Spigot  $\varnothing d_1$  male with a seal (standard)
- female-(indicated by "F" in the product code, e.g. FLX-PRV-R-2-2-0-0-160-F)
- Z no spigots (DIY solution - cutting at the construction site)

# FLX-VNS



## Description

FLX-VNS male couplings are used for joining oval semi-rigid ducts. The plastic couplings are joined with oval ventilation ducting by male connection. They connect long duct section of the domestic ventilation system with heat recovery.

### Product code example

Product code: **FLX-VNS**

type \_\_\_\_\_

## Dimensions

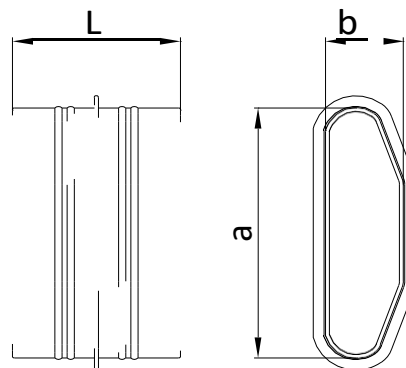

Product code	a [mm]	b [mm]	L [mm]
FLX-VNS	122	38	80

The coupling fits the FLX-HDPE-132-52 ducting.

Inverted male coupling for FLX-HDPE-132-52 oval ducting

# FLX-VODS

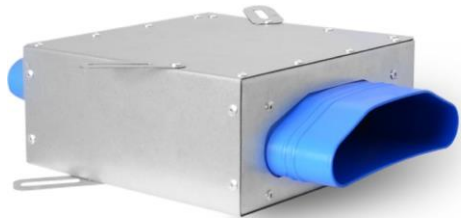

## Dimensions

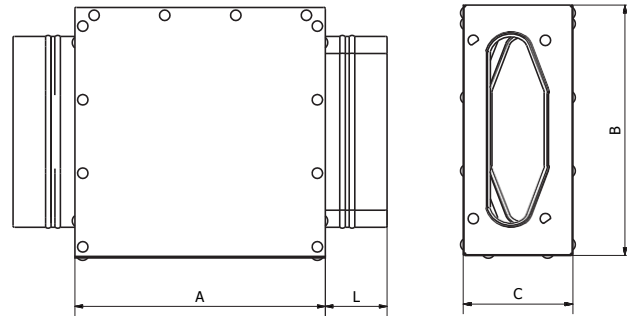

## Description

FLX-VODS inverted male coupling for oval semi-rigid ducting. The inverted male coupling joins oval ducting and inverts the profile of one of the ducts. This solution comes in handy when a plenum box for air supply diffusers need to be connected with the intake upward, or when for some reason ductwork must be installed with the profile upside down.

### Product code example

Product code: **FLX-VODS**

type \_\_\_\_\_

Product code	A [mm]	B [mm]	C [mm]	L [mm]
FLX-VODS-1-1	180	160	70	40

# Plastic elbow for oval semi-rigid ducting FLX-VBH/FLX-VBW



## Description

FLX-VBH/FLX-VBW oval plastic elbow have male ends to connect with HDPE semi-rigid oval ducts sized 132-52 mm.



**FLX-VBH horizontal elbow 90°:** helps with a very complex routing of ductwork bends which would be impossible to make using only ducting.



**FLX-VBW elbow:** enables quick turn upwards of the conducted installation - which is necessary, for example, when running ducts along the floor and then the walls of the room.

### Product code example

Product code: **FLX-VBH**  
type \_\_\_\_\_

## Dimensions

FLX-VBH

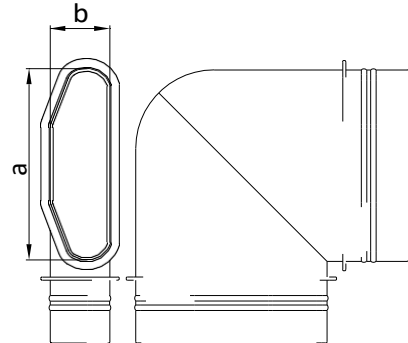

FLX-VBW

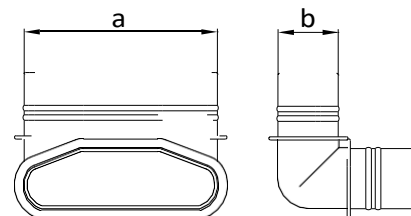

Product code	a [mm]	b [mm]
FLX-VBH	122	38
FLX-VBW	122	38

## Technical data

Pressure loss chart for a 90° elbow

